

WINCHESTER REGIONAL AIRPORT (KOKV) · SOUTHEAST SIDE HANGARS

General aviation hangar specifications

Southeast side hangar condominiums at Winchester Regional Airport (KOKV)



The project comprises eleven hangars, ten approximately 52 feet wide and one approximately 60 feet wide, each approximately 50 feet deep and 18 feet high, grouped into two buildings along the southeast side of the general aviation ramp near the takeoff end of Runway 32. Each hangar is insulated and heated, includes a bathroom in the base configuration, and can be built out with an office, lounge, or other improvements. Shared building systems include central compressed air, internet, electronic access control, common storage, and an outdoor gathering area.

Construction specifications provided by the developer, TMG Construction Corporation. Revised March 2021.

Peter Leonard-Morgan
ASSOCIATE BROKER
(443) 254-5530
peterleonard-morgan@hcsir.com

Charles Thies
REALTOR®
571.509.9918
charles.thies@hcsir.com

Winchester Airport (KOKV) SE Side Hangars 2021 Project Specifications

In General

The scope of this Specification involves the construction of ten new 52'x50' and one 60'x50' x 18' high hangars that are being designed and constructed at KOKV airport. The hangars are grouped into two buildings along the south east side of the general aviation ramp near the takeoff end of runway 32 and are sited such that the back of each hangar has access to the service road and the front directly connects to the ramp. Each of the eleven hangars are insulated, heated and the base option comes with a bathroom and the option of being built out to include an office, lounge and/or other improvements to meet the needs of the individual occupants. Each hangar is part of a larger building, that includes a central compressed air system, internet, electronic access control, a small outdoor picnic area and common storage for the occupants to store items that are of mutual benefit to all occupants in the building. Below is a floor plan for the 5 unit hangar that illustrates the concept. The six unit hangar is similar.

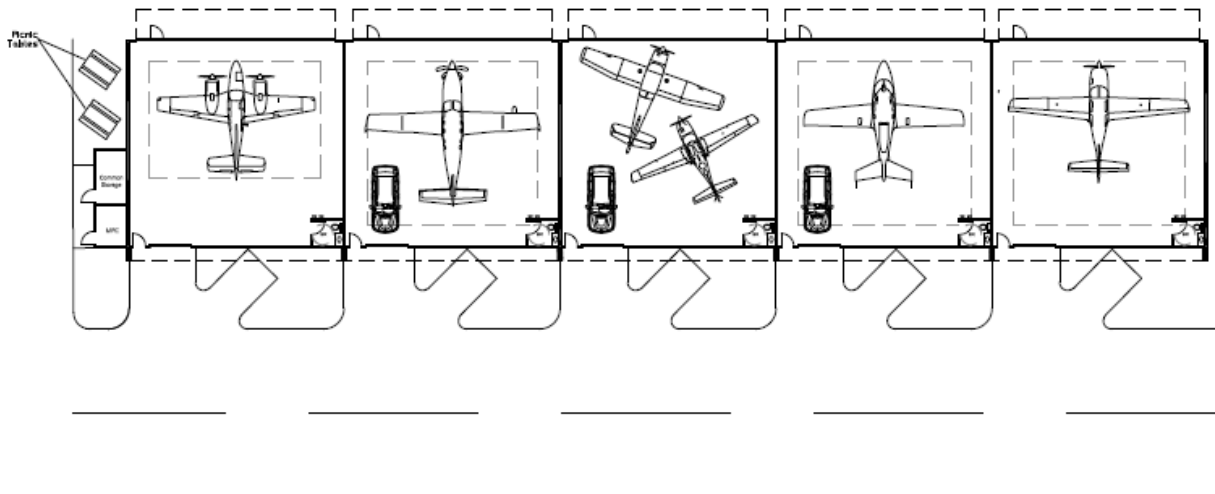

Specifically

The scope of the project is illustrated in ten pages of drawings dated 3.10.2020 that is labeled “Winchester, Virginia Regional Airport General Aviation Hangar Condominium Project Sangars SE Side – Concept Design” and as follows:

Site

The two hangar buildings are sited between the existing ramp area and an existing service road. On the ramp side each individual hangar will be connected to the ramp via asphalt paving. On landside the hangar will be connected to the service road via an asphalt drive way to each hangar’s overhead door, plus one dedicated parking space is provided. A small lawn area on landside is provided.

Structure

Each hangar is a part of a larger building, one containing 5 hangars and the other containing 6 hangars. Each building is constructed of pre-engineered steel, with 26-gauge pre-finished metal siding and a roof that includes a 25-year manufacturer’s warranty. Each hangar has an overall size of 52’ wide x 50’ deep x 18’ high to the lowest purlin in the ceiling system. The structure includes R30 ceiling insulation, R19 wall insulation and 26ga prefinished metal siding installed to 8’ AFF on the interior side of all exterior

Winchester Airport (KOKV) SE Side Hangars 2021 Project Specifications

facing walls to protect the insulation from abuse. The floors are constructed of a 6" concrete slab with vapor barrier that is placed on top of NLT 4" of aggregate.

The structure for each building includes an 8'x10'+/- Mechanical, Plumbing, Electrical (MPE) room, and an 8'x14'+/- storage room that is annexed on the side of the building. The space will provide shelter for the MPE infrastructure of each building and provides storage for items that are common to the occupants of each building.

Architectural Finishes

The base model of each hangar includes the following:

- 48' x 15' (clear open height of 14') bi-fold insulated and motorized hangar door that is manually locked / latched and includes a 3' x 6'-8" +/- hinged integral man-door that includes a closer, weather stripping, keyed lock and electronic access control/ Door. Door shall be provided with a continuous R-16 insulation that is applied over the door framing system that includes a 26ga white aluminum liner – similar or equal to the insulation provided by Diamond Doors.
- 10' x 8' insulated and motorized overhead garage door with a high lift track configuration and a remote control;
- 3' x 6-8" HM insulated grade door to the landside of the hangar that includes a 6"x 24" window, a keyed lock with electronic access control, closer and weather stripping;
- 7'-5"x6'-0" x 9' high +/- bathroom that includes: metal stud and drywall constructed walls and load bearing (125#sf) mezzanine floor / ceiling that creates storage above, a vanity with cultured marble top, toilet, ceramic tile floor and bathroom accessories;
- Interior walls between adjacent hangars are one-hour, fire-rated, painted drywall built with 6" metal studs, R-19 Insulation, Impact rated drywall to 8' AFF and 4" vinyl base;
- All exposed metals will be painted and the floor will be sealed concrete;
- Adjacent to each hangar a small outdoor gathering space is provided that includes two all-weather picnic tables and a trash receptacle;
- Access to the common storage space will be provided via an electronic access-controlled door. Access to the MPE room will be via a keyed lock.

Mechanical Electrical Systems

Plumbing

- Each Building will have a 3/4" metered water service that will provide water to each of the individual hangars;
- Each Building will have a modular 70 gallon sanitary sewer lift station with a single grinder pump that is consistent with those used elsewhere on the airfield;
- Each hangar will be provided with:
 - 36" vanity sink base, cultured marble top and lavatory faucet;
 - Elongated toilet;
 - On demand electric water heater;
 - One hose bib located near bathroom group in the hangar.

Mechanical

- A central air compressor will be located in each building's MPE room. Compressed Air will be piped from the MPE room to each of the hangars via a common header. A regulated air drop will be provided in each hangar.
- Each hangar will be provided with gas fire ceiling mounted radiant heat. Each hangar will be individually metered and each hangar will be provided with a programmable thermostat.

Winchester Airport (KOKV) SE Side Hangars 2021 Project Specifications

- Each hangar's bathroom will be provided with a 1kw electric wall heater that has its own thermostat.

Electrical

- A 600amp 120/240v 1 phase electrical system will be provided to each building. The service will have individually feed 100A – 32 breaker distribution panels located in each hangar and a separate one for common services (house) located in the MPE room. Each hangars service and the house service will be individually metered. Service to each hangar will be provided via a conduit that is sized to allow the service to each hangar to be upgraded to 200A for future consideration of specialty loads such as Air Conditioning.
- The house electrical panel will pickup exterior lighting, electric heat and LED lighting for the MPE and storage room, power to the Air Compressor and 1kW of UPS power for the fire alarm system, internet, and electronic access control equipment.
- Each hangar will be provided with a 32 breaker 120/240v 1 phase distribution system that will power the following loads:
 - Hangar Ceiling Mounted LED Lighting,
 - Motorized Hangar Door,
 - Motorized Overhead door on Landside,
 - Receptacles located at 20' OC on each wall,
 - Bathroom Insta-hot water heater, lighting, GFCI receptacle unit heater and ventilation fan,
- Pendant mounted LED lighting will provide 50 fc of lighting in each hangar. The lighting will be 3way switched with switches located near the two exterior man-doors.
- An electronic access control system will be provided that is an extension of the airports system. Access control will be provided to the two exterior man-doors for each hangar along with access to the common storage area. The access control card will be the same card as is used to gain access to airport grounds via the gates. Administration and programming of the access card will be provided by the Airport Authority.
- A central fire alarm system will be provided for each building that meets the minimum requirements of NFPA and IBC.
- Rough-in (conduit and j boxes) for a CCTV system will be provided for each building.
- The four airfield ramp area poles and electrical feeds will be relocated to the face of the hangar buildings as conceptually illustrated in the drawings;
- An internet connection will be provided to each building that includes a head-end that is located in the MPE room and wifi antennas that are located in each hangar. The wifi system will provide an open network that is regulated at 5 mps and a private network that provides 50 mps of up and download speed.

Optional Features

Base on the individual needs of each condominium hangar's Owners, each hangar can be customized. The following standard options are available:

Option #1 - Interior Option #1 (Refer to Drawing - Page 5) – **1st Floor Lounge, Storage and Bathroom with Open Storage above.** The scope includes:

- a. Painted drywall walls and ceilings utilizing metal stud framing as shown;
- b. 50#/sf LL second floor loft that is provided with an unfinished ¾" plywood floor and a two-line pipe railing system as shown;
- c. A miscellaneous metal pan stair filled with concrete treads and two-line handrail that provides access to the loft;

Winchester Airport (KOKV) SE Side Hangars 2021 Project Specifications

- d. Hollow Metal Door Frames and Wood Doors with keyed locksets on entry doors and a privacy set on the bathroom doors;
- e. Hollow Metal 4' x 8' Window with ¼" glass;
- f. Air conditioned and heated lounge area (DX mini-split);
- g. LED lighting -50 fc (dimable in lounge area);
- h. 24" x 72" maple work bench (Similar Global industries WR3319086);

Lounge Area

- i. Kitchenette to include 30" SS Refrigerator, Microwave, 60" of base cabinets with a built in 16"x16"x8" sink, a Corian top and 90" of wall cabinets;
- j. An allowance of \$4.00/sf for floor finishes;
- k. Painted walls with vinyl base;
- l. Closet with 12" shelf and coat rod;

Bathroom

- m. Painted walls with vinyl base;
- n. Ceramic tile floor and ceramic base;
- o. 36" vanity base with cultured marble top;
- p. Elongated toilet and seat;
- q. 24" x 30" framed mirror & toilet paper dispenser;
- r. 1kw of electric heat and exhaust fan;

Storage

- s. Painted walls with vinyl base;
- t. Sealed concrete floor;
- u. 9lf of chrome adjustable wire shelving 84" tall standards and 5 shelves; and
- v. 30 gal electric water heater.

Option #2 - Interior Option #1 (Refer to Drawing - Page 6) – **1st Floor Lounge, Storage and Bathroom with Office Suite above.** The scope includes:

- a. Painted drywall walls and ceilings utilizing metal stud framing as shown;
- b. 50#/sf LL second floor loft that is provided with a finished ¾" plywood floor;
- c. A miscellaneous metal pan stair filled with concrete treads and two-line handrail that provides access to the 2nd floor office area;
- d. Hollow Metal Door Frames and Wood Doors with keyed locksets on entry doors and a privacy set on the bathroom doors;
- e. Hollow Metal 4' x 8' Window with ¼" glass;
- f. Air-conditioned and heated lounge and second floor area (two separate DX mini-splits);
- g. LED lighting -50 fc (dimable in lounge and office area);
- h. 24" x 72" maple work bench (Similar to Global industries WR3319086);

Lounge Area

- i. Kitchenette to include 30" SS Refrigerator, Microwave, 60" of base cabinets with a built in 16"x16"x8" sink, a Corian top and 90" of wall cabinets;
- j. An allowance of \$4.00/sf for floor finishes;
- k. Painted walls with vinyl base;
- l. Closet with 12" shelf and coat rod;

Bathroom (lower level)

- m. Painted walls with vinyl base;
- n. Ceramic tile floor and ceramic base;

**Winchester Airport (KOKV) SE Side Hangars 2021 Project
Specifications**

- o. 36" vanity base with cultured marble top;
- p. Elongated toilet and seat;
- q. 24" x 30" framed mirror & toilet paper dispenser;
- r. 1kw of electric heat and exhaust fan;

Storage

- s. Painted walls with vinyl base;
- t. Sealed concrete floor;
- u. 9lf of chrome adjustable wire shelving 84" tall standards and 5 shelves;
- v. 30 gal electric water heater;

Office Area (upper level)

- w. An allowance of \$4.00/sf for floor finishes;
- x. Painted walls with vinyl base; drywall ceiling;
- y. Closet with 12" shelf and coat rod;

Bathroom (upper level)

- z. Painted walls with vinyl base;
- aa. Ceramic tile floor and ceramic base;
- bb. Combination tub / shower with shower curtain;
- cc. 36" vanity base with cultured marble top;
- dd. Elongated toilet and seat;
- ee. 24" x 30" framed mirror, toilet paper dispenser and 18" towel bar
- ff. 1kw of electric heat and exhaust fan;

Option #3 - Air condition for the hangar (30 degree temperature drop @ 70% RH);

Option #4 - Epoxy floor;

Option #5 - Auto latching system for hangar door with 2 RF remote Controls;

Option #6 – 55" wall mounted smart TV with IP connection;

Option #7 - 24" x 96" maple work bench (Global industries WR3319086).

-- End --



Winchester Regional Airport (KOKV) hangars

Peter Leonard-Morgan
ASSOCIATE BROKER

(443) 254-5530
peterleonard-morgan@hcsir.com

Charles Thies
REALTOR®

571.509.9918
charles.thies@hcsir.com

Home. Land. Legacy.